

SafeGuard™ H2O

Hexavalent Chromium (Cr6) Removal Demonstration System

Utilities seeking an affordable and reliable hexavalent chromium (Cr6) remediation solution that complies with California's new 10-ppb MCL regulation will want to look at the SafeGuard™ H2O Cr6 removal system from AMS. Our NSF-approved Reduction/Coagulation/Filtration system is a designated Best Availability Technology (BAT) for Cr6 removal.

SafeGuard™ H2O is a fully automated system designed as a completely self-contained trailer. It is ready to operate when it arrives onsite, making demonstrating Cr6 removal easier and more accessible than ever before. The system has an online Cr analyzer to monitor influent and effluent contaminant levels in real-time, while AMS remotely monitors the system and analyzer operation and performance 24/7/365.

SafeGuard™ H2O produces a non-toxic stannous reagent onsite and on-demand using an in-situ electrolytic generator and a certified precursor. This means that utilities can remove Cr6 from their water supply quickly and efficiently, without worrying about introducing harmful chemicals into the environment.

With its rapid deployability and competitive financing terms, SafeGuard™ H2O is the perfect solution for utilities looking to comply with the new MCL regulations without breaking the bank.

Contact us today to learn more about how SafeGuard™ H2O can help you comply with the new MCL regulation and keep your water supply safe and clean for years to come!

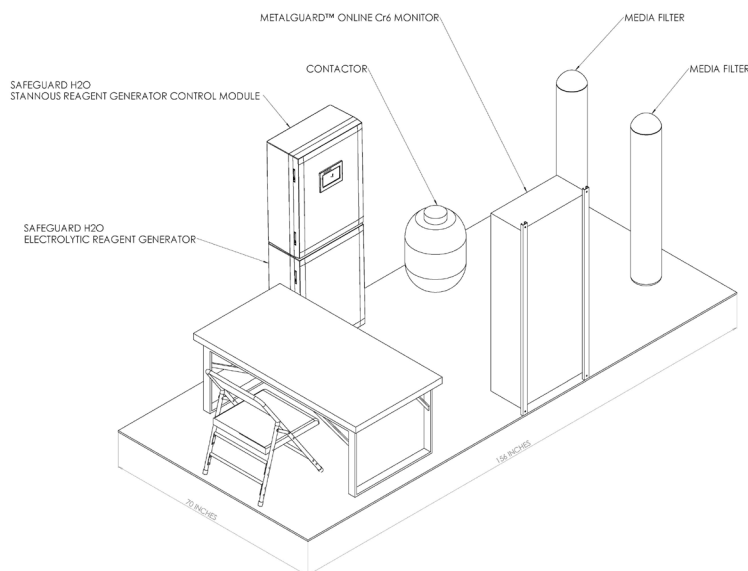

SafeGuard™ H2O Cr6 Removal Demonstration Trailer comprises five main components: the stannous reagent generation control module, electrolytic reagent generator, contactor, sand media filter and the MetalGuard™ online Cr6 monitor.

T: +1 408-523-1900 x999 | E: cr6@ams-h2o.com



SafeGuard™ H2O
On-Site Stannous
Generation System
Specification



Compared to other Cr6 removal treatment processes, SafeGuard™ H2O offers utilities numerous operational and process benefits.

Table 1: Comparison of Hexavalent Chromium (Cr6) Removal Treatment Processes

	Ferrous RCF	Ion Exchange	SafeGuard™ H2O
GHG Emissions	Medium	High	Low
Interferences	Medium-High	High	None
Reagent Dose	High	None	Low
Sludge Generation	High	None	Low
Toxic Residuals	None	Yes	None
System Footprint	Large	Medium-Large	Low
Latency	High	Medium-High	Low
Process Controllability	Low-Medium	Low-Medium	High
Overall Complexity	High	High	Low
Cost	\$\$\$	\$\$\$\$	\$

- GHG Emissions: Amount of GHG emissions emitted by using the technology.
- Interferences: Effect of water quality parameters and interferences on treatment process performance.
- Reagent Dose: Amount of reagents needed to treat a unit of water volume (mg/L, ppm, etc)
- Sludge Generation: Amount of sludge generated by the treatment process per volume of treated water.
- Toxic Residuals: Identifies if the process generates a toxic residual.
- System Footprint: Footprint and space required by the treatment process equipment.
- Latency: Time period between when a treatment system process change is (re)initiated and water quality complies.
- Process Controllability: Ability to control the treatment process without requiring multiple and difficult approaches with a high risk of failure.
- Overall Complexity: Level of complexity the treatment process requires from the water system and treatment/operational staff.
- Cost: Cost to treat a unit of water volume (Ex: per thousand gallons).

