

FEATURES

Universal design for use with Hub and Lateral or side entry lateral underdrains and multiple distribution systems.

Design:

- 100 PSIG ASME Code Stamped for 150F

Lining:

- Sherplate 600 10-20 MILS total DFT
- Meets NSF-600/NSF-61

Exterior Paint:

- Macropoxy 646 5-10 MILS, Acrolon 218 Topcoat 3-6 MILS DFT.

Internal Pipe Hangers:

- Upper and lower hangers included in vessels 48" diameter and larger.

Flange Connections:

- Internal DTPF flange holes sealed with nylon plugs.



OPTIONS

- Left hand model for duplex systems.
- Sight glass assembly or blind flanges for unused ports.
- Custom skid fabrication.
- Installation of customer supplied internals.
- Vessel leg length modification.
- Lateral and distributor fabrication per customer design in carbon, stainless and PVC.

STOCK SIZES AVAILABLE:

DIAMETER	SHELL	OAH	VOLUME	DWG#	PRICE EACH
36	60	92.5	310 G	BS036060C009	\$ 9,650
36	72	104.5	363 G	BS036072C003	\$ 10,215
48	60	100.5	586 G	BS048060C007	\$ 13,546
48	72	112.5	679 G	BS048072C006	\$ 14,273
60	60	106.5	967 G	BS060060C005	\$ 16,926
60	72	118.5	1112 G	BS060072C002	\$ 18,584

Note: Check stock availability before ordering. Left hand models subject to current lead time.

*Quoted prices effective 1/29/2024 may be subject to change at time of order.

Sales Contacts:

Chris Doyle - VP of Sales, ext 227
Michael Jackson - Estimating, ext 212

E: ced@universaltank.com
E: sales@universaltank.com

Universal Tank & Fabrication

8025 Chavenelle Rd. • Dubuque, IA 52002
563-556-5889 • F: 563-556-5870

UNIVERSAL TANK & FABRICATION

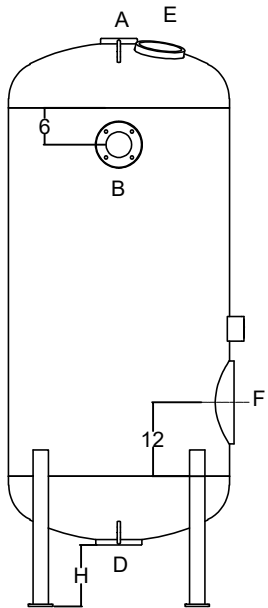
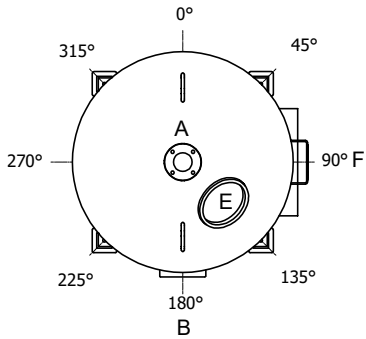

UTF-WTR DOUBLE TAP FLANGE SERIES / 100 PSI ASME / NSF-61 / NSF-600 LINED "UNIVERSAL" DESIGN FOR USE WITH HUB OR LATERAL UNDER-DRAINS AND MULTIPLE DISTRIBUTION SYSTEM DESIGNS						
DIAMETER / SHELL LENGTH / OAH						
SCHEDULE	36 X 60 X 92.5	36 X 72 X 104.5	48 X 60 X 100.5	48 X 72 X 112.5	60 X 60 X 106.5	60 X 72 X 118.5
VOLUME	310 G	363 G	586 G	679 G	967 G	1112 G
WEIGHT	727 LBS	808 LBS	1179 LBS	1285 LBS	1949 LBS	2117 LBS
A	2" DTPF	2" DTPF	3" DTPF	3" DTPF	3" DTPF	3" DTPF
B	3" DTPF	3" DTPF	4" DTPF	4" DTPF	4" DTPF	4" DTPF
C	-----	-----	4" DTPF	4" DTPF	4" DTPF	4" DTPF
D	3" DTPF	3" DTPF	4" DTPF	4" DTPF	4" DTPF	4" DTPF
E	6" X 8"	6" X 8"	12" X 16"	12" X 16"	12" X 16"	12" X 16"
F	12" X 16"	12" X 16"	12" X 16"	12" X 16"	12" X 16"	12" X 16"
G	-----	-----	(2) PIPE HNGR	(2) PIPE HNGR	(2) PIPE HNGR	(2) PIPE HNGR
H	10"	10"	12"	12"	12"	12"
DRAWING NUMBER	BS036060C009	BS036072C003	BS048060C007	BS048072C006	BS060060C005	BS060072C002
EXT. PAINT	1 COAT MACROPOXY 646 5-10 MILS, 1 COAT ACROLON 218 3-6 MILS "UNIVERSAL BLUE"					
INT. LINING	(2) COATS SHERPLATE 600 10-20 MILS TOTAL DFT					
OPTIONS	3" OR 4" SIGHT GLASS W/ COVER FOR USED PORT(S)					
**	3" OR 4" BLIND FLANGES FOR UNUSED PORT(S)					
NOTES						
**	NAME PLATE BRACKET, (2) LIFT LUGS & (1) TAILING LUG INCLUDED					

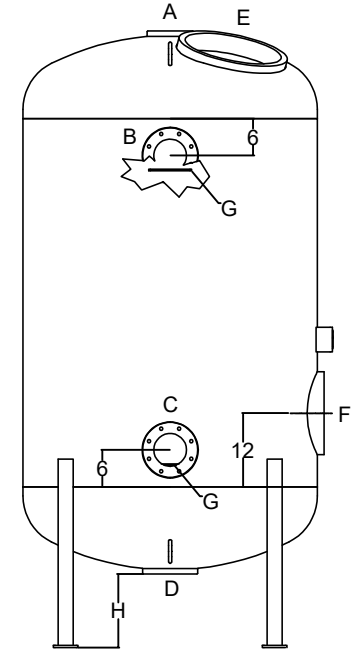
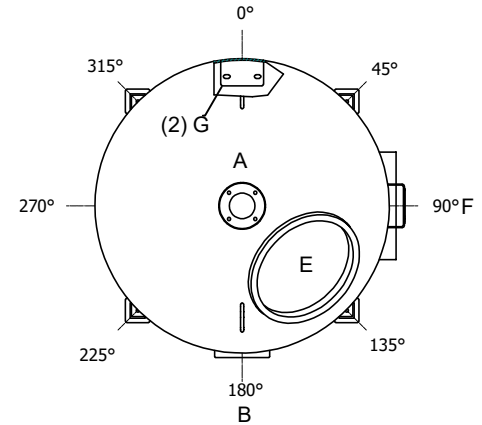

Sales Contacts:

Chris Doyle - VP of Sales, ext 227
Michael Jackson - Estimating, ext 212

E: ced@universaltank.com
E: sales@universaltank.com

Universal Tank & Fabrication

8025 Chavenelle Rd. • Dubuque, IA 52002
563-556-5889 • F: 563-556-5870