

# WHAT IS pH AND HOW IS IT MEASURED?

A Technical Handbook for Industry

## **CHAPTER 1 – INTRODUCTION**

Why Is pH Measurement Necessary? _____	3
--	---

## **CHAPTER 2 – WATER AND AQUEOUS SOLUTIONS**

The Properties of Water _____	4
Ion Product Constant of Water _____	4
Molarity _____	5

## **CHAPTER 3 – FUNDAMENTALS OF pH**

Definition of pH _____	6
pH Values and Hydrogen/Hydroxide Concentration _____	6
How is pH Measured? _____	7
Activity versus Concentration _____	7
The Nernst Equation _____	9
The Standard Hydrogen Electrode _____	9

## **CHAPTER 4 – THE pH SENSOR**

pH Electrodes _____	11
The Measuring Electrode _____	13
Asymmetry Potential _____	13
Sodium Ion Error _____	14
Acid Error _____	15
Temperature Effects _____	15
The Reference Electrode _____	16
The Reference Junction _____	17
Junction Potentials _____	17
Gel-filled Reference Electrode _____	18
Buffers _____	18
Calibration _____	18

## **CHAPTER 5 – CARE OF pH ELECTRODES**

Dehydration _____	22
Factors Detrimental to Electrode Life _____	22
Transportation _____	22
Storage _____	23

## **CHAPTER 6 – COMMON APPLICATIONS**

Cooling Tower Control _____	24
Food Processing _____	24
Coal Industry _____	24
Plating Waste Treatment _____	25
Ultrapure Water _____	25

<b>BIBLIOGRAPHY</b> _____	27
---------------------------	----

<b>GLOSSARY</b> _____	28
-----------------------	----

# Chapter 1 – INTRODUCTION

## Why Is pH Measurement Necessary?

Almost all processes containing water have a need for pH measurement. Most living things depend on a proper pH level to sustain life. All human beings and animals rely on internal mechanisms to maintain the pH level of their blood. The blood flowing through our veins must have a pH between 7.35 and 7.45. Exceeding this range by as little as one-tenth of a pH unit could prove fatal.

Commodities such as wheat and corn, along with other plants and food products, will grow best if the soil they are planted in is maintained at an optimal pH. To attain high crop yields, farmers must condition their fields to the correct pH value. Different crops need different pH levels. In this case, one size does not fit all.

Acid rain can be very detrimental to crop yields. Rainwater is naturally acidic (below 7.0 pH). Rain is typically around 5.6 pH but, in some areas, it increases to harmful levels between 4.0 and 5.0 pH due to atmospheric pollutants. Heavily industrialized areas of the US, such as the Midwest, have been targeted by various environmental agencies to minimize the pollutants that cause acid rain. The burning of fossil fuels like coal, releases gases into the upper atmosphere that, when combined with rain water, change composition and cause the rain water to become more acidic.

Proper pH control keeps milk from turning sour, makes strawberry jelly gel, and prevents shampoo from stinging your eyes. In plating plants, pH control is used to ensure the luster of chrome on various products from nuts and bolts to toasters and automobile bumpers. The pH of wastewater leaving manufacturing plants and wastewater purification plants, as well as potable water from municipal drinking water plants, must be within a specific pH "window" as set forth by local, state or federal regulatory agencies. This value is typically between 5 and 9 pH, but can vary from area to area.

Other pH applications include:

- Neutralization of effluent in steel, pulp and paper, chemical, and pharmaceutical manufacturing
- Hexavalent chromium destruction
- Cyanide destruction
- Reverse osmosis
- Odor scrubbers
- Pharmaceutical manufacturing
- Chemical and petrochemical manufacturing
- Cooling tower control

Whether adjusting the pH for a proper reaction or making sure wastewater is at the proper pH value before sending it to the community sewer system, accurate pH measurement is required. Put simply, pH is an integral part of our everyday life.

# Chapter 2 – WATER AND AQUEOUS SOLUTIONS

## The Properties of Water

Water is the most common substance known to man, and is the most important. In vapor, liquid or solid form, water covers more than seventy percent of the Earth's surface, and is a major component of the atmosphere. Water is also an essential requirement for all forms of life. Most living things are largely made up of water. Human beings, for example, consist of about two-thirds water.

Pure water is a clear, colorless, and odorless liquid made up of one oxygen and two hydrogen atoms. The Italian scientist Stanislao Cannizzarro defined the chemical formula of the water molecule, H<sub>2</sub>O, in 1860. Water is a very powerful substance that acts as a medium for many reactions, which is why it is often referred to as the "universal solvent." Although pure water is a poor conductor of electricity, impurities that occur naturally in water transform it into a relatively good conductor. Water has unusually high boiling (100°C/212°F) and freezing (0°C/32°F) points. It also shows unusual volume changes with temperature. As water cools, it contracts to a maximum density of 1 gram per cubic centimeter at 4°C (39°F). Further cooling actually causes it to expand, especially when it reaches the freezing point. The fact that water is denser in the liquid form than the solid form explains why an ice cube floats in a beverage, or why a body of water freezes from the top down. While the density property of water is of little importance to the beverage example, it has a tremendous impact on the survival of aquatic life inhabiting a body of water.

## Ion Product Constant of Water

Water molecules are in continuous motion, even at lower temperatures. When two water molecules collide, a hydrogen ion is transferred from one molecule to the other (*Figure 1*). The water molecule that loses the hydrogen ion becomes a negatively charged hydroxide ion. The water molecule that gains the hydrogen ion becomes a positively charged hydronium ion. This process is commonly referred to as the **self-ionization of water**.

**Figure 1. Self Ionization of Water**

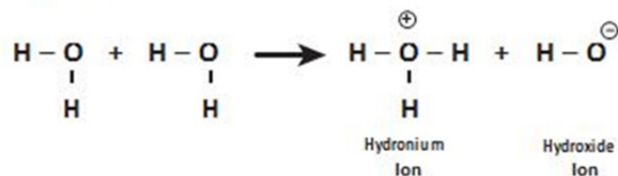

The self-ionization of water does not regularly occur. This reaction can be written as a simple dissociation (*Figure 2*). At 25° C in pure water, each concentration of hydrogen ions and hydroxide ions is only  $1 \times 10^{-7}$  M. It is important to note that the number of hydrogen and hydroxide ions produced from this reaction is equal. This is why pure water is often described as a **neutral solution**.

**Figure2. Dissociation of Water**

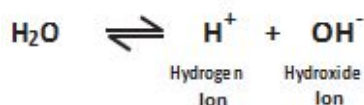

In all other aqueous solutions, the relative concentrations of each of these ions is unequal. When more of one ion is added to the solution, the concentration of the other decreases. The following equation describes this relationship:

$$[\text{H}^+][\text{OH}^-] = 1 \times 10^{-14} (\text{mol/L})^2 = K_w$$

The product of the hydrogen and hydroxide ions is always equal to  $1 \times 10^{-14} (\text{mol/L})^2$ . Therefore, if the concentration of one ion increases by a factor of 10, then the concentration of the other ion must decrease by a factor of 10. Since this relationship is constant, it is given the symbol  $K_w$ , which is called the **ion-product constant for water**.

Aqueous solutions that have a hydrogen ion concentration greater than the hydroxide ion concentration are called **acidic solutions**. When the hydroxide ion concentration is greater than the hydrogen ion concentration, the solution is called **basic or alkaline**.

## Molarity

The term "molarity" describes the concentration of a substance within a solution. By definition, a one "molar" solution of hydrogen ion contains one "mole" of hydrogen ion per liter of solution. Therefore, a solution of 10 pH has  $1 \times 10^{-10}$  moles of hydrogen ions as shown by the following equation:

$$1 \times 10^{-10} \text{ mol} = \frac{1 \times 10^{-10} \text{ g hydrogen ion}}{1 \text{ L}}$$

Furthermore, a solution of 4 pH has  $1 \times 10^{-4}$  moles of hydrogen ions, and so on. This also means that one liter of a pH 10 solution would contain  $1 \times 10^{-10}$  grams of hydrogen ion, because 1 mole = 1 g/L for hydrogen.

A one molar solution of sodium hydroxide (NaOH), a base, is approximately 4% by weight, and has a pH value of 14. A one molar solution of hydrochloric acid (HCl), an acid, is approximately 3.7% by weight, and has a pH of 0. By diluting either of these two solutions, the molarity will decrease as well. For example, diluting 1 ml of HCl acid by adding 9 ml of distilled water results in a 0.1 molar hydrochloric acid solution, which has a pH value of 1.0. Diluting sodium hydroxide using the same volumes yields a solution with a pH value of 13. If this dilution procedure were continued, the pH of each solution would approach a neutral pH of 7.

**NOTE: For every 10-fold change in concentration (example: 0.1 to 1.0), the pH changes by one unit.**

If equal volumes of 4 pH (0.0001M HCl) and 10 pH (0.0001 NaOH) solutions were mixed together, the resultant solution would have a pH of 7.

**NOTE: HCl and NaOH have opposing  $[\text{H}^+]/[\text{OH}^-]$  concentrations.**

The same result would apply when mixing equal volumes of a 6 pH acid and an 8 pH base, a 2 pH acid and a 12 pH base, and so on.

## Chapter 3 - FUNDAMENTALS OF pH

### Definition of pH

Just as the kilometer is a measure of distance and the hour is a measure of time, the pH unit measures the degree of acidity or basicity of a solution.

To be more exact, pH is the measurement of **the hydrogen ion concentration**,  $[H^+]$ . Every aqueous solution can be measured to determine its pH value. This value ranges from 0 to 14 pH. Values below 7 pH exhibit acidic properties. Values above 7 pH exhibit basic (also known as caustic or alkaline) properties. Since 7 pH is the center of the measurement scale, it is neither acidic nor basic, it is called "neutral."

**pH** is defined as the **negative logarithm of the hydrogen ion** concentration. This definition of pH was introduced in 1909 by the Danish biochemist, Soren Peter Lauritz Sorensen. It is expressed mathematically as:

$$\text{pH} = -\log [H^+]$$

where:  $[H^+]$  is hydrogen ion concentration in mol/L

The pH value is an expression of the ratio of  $[H^+]$  to  $[OH^-]$  (hydroxide ion concentration). Hence, if the  $[H^+]$  is greater than  $[OH^-]$ , the solution is acidic. Conversely, if the  $[OH^-]$  is greater than the  $[H^+]$ , the solution is basic. At 7 pH, the ratio of  $[H^+]$  to  $[OH^-]$  is equal and, therefore, the solution is neutral. As shown in the equation below, pH is a logarithmic function. A change of one pH unit represents a 10-fold change in concentration of hydrogen ion. In a neutral solution, the  $[H^+] = 1 \times 10^{-7}$  mol/L. This represents the pH of 7.

$$\begin{aligned} \text{pH} &= -\log (1 \times 10^{-7}) \\ &= -(\log 1 + \log 10^{-7}) \\ &= -(0.0 + (-7)) \\ &= 7.0 \end{aligned}$$

Since the concentration of hydrogen ions and hydroxide ions is constant in a stable solution, either one can be quantified if the value of the other is known. Therefore, when determining the pH of a solution, (even though the hydrogen ion concentration is being measured), the hydroxide ion concentration can be calculated:

$$[H^+][OH^-] = 10^{-14}$$

### pH Values and Hydrogen/Hydroxide Concentrations

In *Figure 3*, the pH value corresponds to the number of decimal places under the column for "hydrogen ion concentration." The pH of the solution equals the exponential form of the  $[H^+]$ , with the minus sign changed to a plus. It is much easier to write or say "10 pH" than it is to communicate "a hydrogen-ion concentration of 0.000000001 mol/L."

Figure 3. Table of Relative  $[\text{OH}^-]$  and  $[\text{H}^+]$  Mol/Liter Concentrations

	$[\text{OH}^-]$ concentration (mol/l)	pH	$[\text{H}^+]$ concentration (mol/l)		
$1 \times 10^{-14}$	0.000000000000001	0	1	$1 \times 100$	 Increasing acidity  Neutral  Increasing basicity
$1 \times 10^{-13}$	0.00000000000001	1	0.1	$1 \times 10^{-1}$	
$1 \times 10^{-12}$	0.0000000000001	2	0.01	$1 \times 10^{-2}$	
$1 \times 10^{-11}$	0.000000000001	3	0.001	$1 \times 10^{-3}$	
$1 \times 10^{-10}$	0.0000000001	4	0.0001	$1 \times 10^{-4}$	
$1 \times 10^{-9}$	0.000000001	5	0.00001	$1 \times 10^{-5}$	
$1 \times 10^{-8}$	0.00000001	6	0.000001	$1 \times 10^{-6}$	
$1 \times 10^{-7}$	0.0000001	7	0.0000001	$1 \times 10^{-7}$	
$1 \times 10^{-6}$	0.000001	8	0.00000001	$1 \times 10^{-8}$	
$1 \times 10^{-5}$	0.00001	9	0.000000001	$1 \times 10^{-9}$	
$1 \times 10^{-4}$	0.0001	10	0.0000000001	$1 \times 10^{-10}$	
$1 \times 10^{-3}$	0.001	11	0.00000000001	$1 \times 10^{-11}$	
$1 \times 10^{-2}$	0.01	12	0.000000000001	$1 \times 10^{-12}$	
$1 \times 10^{-1}$	0.1	13	0.0000000000001	$1 \times 10^{-13}$	
$1 \times 100$	1	14	0.00000000000001	$1 \times 10^{-14}$	

## How Is pH Measured?

pH in an aqueous solution can be measured in a variety of ways. The most common way uses a pH-sensitive glass electrode, a reference electrode and a pH meter. Alternative methods for determining the pH of a solution are:

- **Indicators:** Indicators are materials that are specifically designed to change color when exposed to different pH values. The color of a wetted sample paper is matched to a color on a color chart to infer a pH value. pH paper is available for narrow pH ranges (for example, 3.0 to 5.5 pH, 4.5 to 7.5 pH and 6.0 to 8.0 pH), and fairly wide pH ranges of 1.0 to 11.0 pH.

**NOTE:** pH paper is typically used for preliminary and small volume measuring. It cannot be used for continuous monitoring of a process. Though pH paper is fairly inexpensive, it can be attacked by process solutions, which may interfere with the color change.

- **Colorimeter:** This device uses a vial filled with an appropriate volume of sample to which a reagent is added. As the reagent is added, a color change takes place. The color of this solution is then compared to a color wheel or spectral standard to interpolate the pH value.

The colorimeter can be used for grab sample measuring, but not for continuous on-line measuring. Typically used to determine the pH value of water in swimming pools, spas, cooling towers, and boilers, as well as lake and river waters.

A pH meter is always recommended for precise and continuous measuring. Most laboratories use a pH meter connected to a strip chart recorder or some other data acquisition device so that the reading can be recorded or stored electronically over a user-defined time range.

## Activity versus Concentration

Glass electrodes are sensitive to the hydrogen ion **activity** in a solution. Consequently, the concentration of hydrogen ion is not the only factor influencing the pH of a solution. The concentration of other chemicals in the solution, or the **ionic strength** of the solution, is also a major influence in the measurement of pH.

The term "ionic strength" describes the amount of ionic species in a solution, as well as the magnitude of charge on those species. Examples of ion species compounds are sodium ( $\text{Na}^+$ ) sulfate ( $\text{SO}_4^{2-}$ ), calcium ( $\text{Ca}^{2+}$ ) chloride ( $\text{Cl}^-$ ), and potassium ( $\text{K}^+$ ) nitrate ( $\text{NO}_3^-$ ). Presence of these ions in solution tends to limit the mobility of the hydrogen ion, thereby decreasing the activity of  $\text{H}^+$ .

The concept of limited mobility of the hydrogen ion is analogous to a person entering a shopping mall. If the shopping crowd is very small, the person is free to move about the mall in any direction. However, if the mall is very crowded, the shopper has a difficult time moving from store to store, which severely limits their activity. It is this same principle of a "crowded environment" that limits the activity of the hydrogen ion.

The following equation mathematically describes this effect on the activity of  $\text{H}^+$ :

$$\text{pH} = -\log \{[\text{H}^+] \times [f]\}$$

where:  $f$  is the activity coefficient

In solutions where the ionic strength is very low, the activity coefficient is 1.00, making the activity of hydrogen ion equal to its concentration. As the ionic strength of a solution increases, the activity coefficient decreases. This has the effect of lowering the activity of hydrogen ion, which is seen as an increase in pH. The following example illustrates this point:

**Example:** The pH of a 0.00002 M solution of nitric acid can be calculated using this equation:

$$\text{pH} = -\log \{[\text{H}^+] \times [f]\}$$

$$\text{pH} = -\log \{[0.00002] \times [1]\}$$

$$\text{pH} = 4.70$$

The value of  $[f]$  can be derived from various equations, or found in published tables:

CRC Handbook of Chemistry and Physics by Robert C. West, Ph.D., Ed., CRC Press, Inc., Boca Raton, FL

Lange's Handbook of Chemistry by John A. Dean, Ph.D., Ed., McGraw-Hill Book Company, NY, NY

The product of the activity coefficient and hydrogen ion concentration is equal to 0.00002. This means that the ionic strength of the solution has no effect on the pH calculation.

If the ionic strength were 0.1, the new pH can be calculated using this equation:

$$\text{pH} = -\log \{[\text{H}^+] \times [f]\}$$

$$\text{pH} = -\log \{[0.00002] \times [0.75]\}$$

$$\text{pH} = 4.82$$

If the ionic strength of the solution were 0.1, the activity coefficient,  $[f]$ , would then be 0.75. The product of the activity coefficient and hydrogen ion concentration is now less than 0.00002. This causes the pH calculation of the nitric acid solution to increase by 0.12 pH unit. In this case, the ionic strength has a major influence on the pH of the solution.



## The Nernst Equation

The general mathematical description of electrode behavior was described by the 19th century German chemist, Hermann Walther Nernst (1864 - 1941). He introduced the Nernst equation in 1889, expressed as:

$$E = E_0 - \frac{2.3RT}{nF} \log a_i$$

where:

E = total potential (in millivolts) between two electrodes

$E_0$  = standard potential of the ion

R = universal gas constant (in Joules/mol-Kelvin)

T = absolute temperature (in Kelvin)

n = charge of the ion

F = Faraday constant (in Coulombs/mol)

$a_i$  = activity of the ion

The entire term " $2.3RT/nF$ " is called the Nernst factor, or slope factor. This term provides the amount of change in total potential for every ten-fold change in ion concentration. For hydrogen ion activity, where  $n = 1$ , the Nernst factor is 59.16 mV for every ten-fold change in activity at 25°C. This means that for every pH unit change, the total potential will change 59.16 mV.

The following general equation may be stated for any temperature (since pH is defined as the negative logarithm of the hydrogen ion activity):

$$E = E_0 + (1.98 \times 10^{-4}) T_K \text{ pH}$$

However, the Nernst factor will change when temperature changes; T is not constant. At 25° C the slope of the pH electrode is 59.16 mV/pH unit. At 0° C the slope value is approximately 54 mV/pH, and at 100° C the slope value is approximately 74 mV/pH. The millivolt output of the glass pH electrode will change with temperature in accordance with the Nernst equation. As the temperature increases, so does the millivolt output. Specifically, the slope of the electrode is what changes.

The change in electrode output versus temperature is linear, which can be compensated in the pH meter. The linear function for temperature vs. pH change can be expressed as:

$$0.003 \text{ pH error/pH unit/}^\circ\text{C}$$

If an uncompensated pH system were standardized in pH 7 buffer at 25° C, and then a sample at 23° C measured 4.00 pH, the error would be 0.018 pH unit ( $.003 \times 2^\circ \text{ C} \times 3 \text{ units}$ ). For a measurement of 4.00 pH at 75° C (probably close to a typical worst case), an uncompensated pH system would read 4.45 pH.

## The Standard Hydrogen Electrode

The glass measuring electrode has its electrochemical roots planted in the earlier use of the standard hydrogen electrode (SHE). The SHE is the universal reference for reporting relative half-cell potentials. A type of gas electrode, it was widely used in early studies as a reference electrode and as an indicator electrode for the

determination of pH values. The SHE could be used as either an anode or cathode depending upon the nature of the half-cell it is used with.

The SHE consists of a platinum electrode immersed in a solution with a hydrogen ion concentration of 1.00M. The platinum electrode is made of a small square of platinum foil, which is platinized with a finely divided layer of platinum (known as platinum black). Hydrogen gas, at a pressure of 1 atmosphere, is bubbled around the platinum electrode. The platinum black serves as a large surface area for the reaction to take place, and the stream of hydrogen keeps the solution saturated at the electrode site with respect to the gas.

It is interesting to note that even though the SHE is the universal reference standard, it exists only as a theoretical electrode that scientists use as the definition of an arbitrary reference electrode with a half-cell potential of 0.00 volts. Because half-cell potentials cannot be measured, this is the perfect electrode to allow scientists to perform theoretical research calculations. The reason this electrode cannot be manufactured because no solution can be prepared that yields a hydrogen ion activity of 1.00M.

# Chapter 4 – THE pH SENSOR

## pH Electrodes

A pH electrode assembly, or sensor, consists of two primary parts:

- **Measuring electrode:** The measuring electrode is sometimes called the glass electrode, and is also referred to as a membrane or active electrode.
- **Reference electrode:** The reference electrode is also referred to as a standard electrode.

Figure 4 shows these two electrodes.

The pH measurement is comprised of two half-cell, or electrode, potentials. One half-cell is the pH sensitive glass measuring electrode and the other is the reference electrode. Just as the two half-cell potentials of a battery are required to complete a circuit so does a pH sensor.

The mathematical expression for this is:

$$E = E_m - E_r$$

where:

$E_m$  = the electrode potential of the measuring electrode

$E_r$  = the electrode potential of the reference electrode

This type of measurement, in millivolts, is called a potentiometric measurement.

Since voltage-measuring devices only determine differences in potentials, there is no method for determining the potential of a single electrode. A galvanic measurement circuit is formed by connecting the measuring electrode (half-cell potential) and the reference electrode (half-cell potential) to the signal input of the measuring device. At the reference electrode, there is a solid/solution interface, where a chemical reaction takes place. This enables an electrical current to flow through the measuring device, the pH meter, which allows the reading to be made (Figure 5).

Since the current that passes through the half-cells and the solution being measured is extremely small, the pH meter must have a high internal impedance, so it does not "drag down" the millivolt potential produced by the electrodes. This low current flow ensures that the chemical characteristics of the solution being measured remains unaltered.

A galvanic potential is formed when charge exchanges occur at the phase boundaries of the glass measuring electrode. In effect, the pH sensor assembly forms a galvanic cell using two metal conductors—lead wires of the measuring and reference electrodes interconnected through their respective electrolyte solutions—and the

Figure 4. Electrode Pair

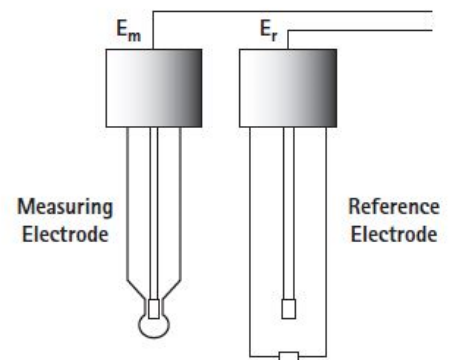
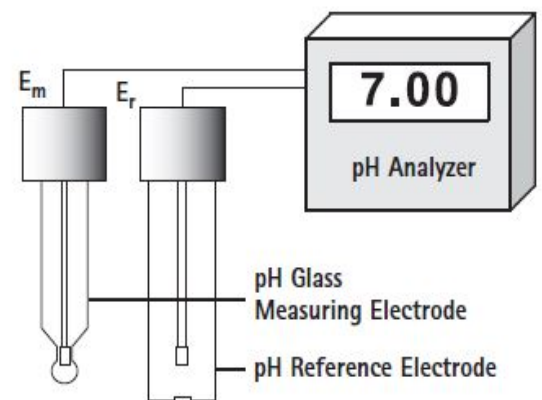

Figure 5. pH Measurement Circuit



media. Since phase boundaries cannot be measured individually and there are always more than two phase boundaries present, the pH meter measures the overall potential. The **overall potential** is comprised of the following elements:

- Metal lead-out wire of the measuring electrode
- Electrolyte of the measuring electrode
- Diffusion potentials at solid/solution interfaces
- Electrolyte of the reference electrode
- Metal lead-out wire of the reference electrode

The measuring and reference electrodes can be in one of two forms: two physically separate electrodes, known as an electrode pair; or the electrodes can be joined together in a single glass body assembly known as a combination electrode (Figure 6).

Figure 6. Combination Electrode

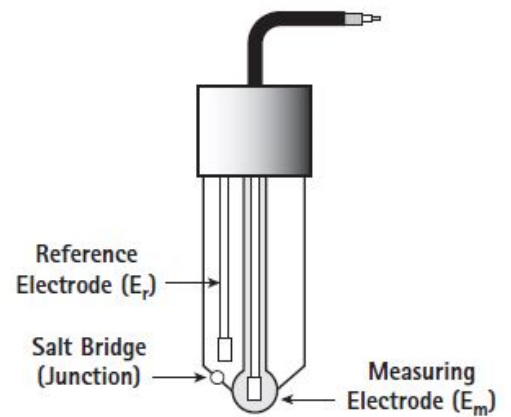

The electrode pair and combination electrode styles originated many years ago and continue to be widely used today. In the 1970s, a different style pH sensor was developed and patented specifically for continuous on-line measurement applications. This pH sensor uses a **differential electrode technique** (Figure 7) that employs two pH glass measuring electrodes. One electrode is used as the active or measuring electrode, and the other is used as part of a reference assembly. The reference assembly consists of a pH glass measuring electrode immersed in a 7 pH buffer solution which is mechanically isolated from the solution being measured by a double junction "salt bridge" (see "The Reference Junction" subsection on page 14 for details). These two half-cell potentials are then referenced to a third ground electrode.

The differential electrode technique is expressed as:

$$E_{out} = [(E_m - E_g) - (E_r - E_g)]$$

where:

$E_m$  = measuring electrode voltage

$E_r$  = reference electrode assembly voltage

$E_g$  = solution ground electrode voltage

After canceling the  $E_g$  term:

$$E_{out} = E_m - E_r$$

Other major components of the differential pH sensor include the sensor cable, a temperature compensation device, electrolyte solutions, and reference junctions.

Based on field-proven results, the differential electrode technique has shown marked advantages over conventional electrode pairs and combination electrodes. The double junction salt bridge (part of the reference assembly) makes it extremely difficult for an appreciable amount of the solution being measured to migrate into the inner chamber. Since the inner chamber is filled with a buffer, a 100 to 1 dilution would only represent a change in measured pH of 0.05 pH units. Similar dilutions to the conventional reference electrode used in electrode pairs or combination electrodes could cause shifts of up to 2.0 pH units.

Figure 7. Differential Electrode Measurement Technique

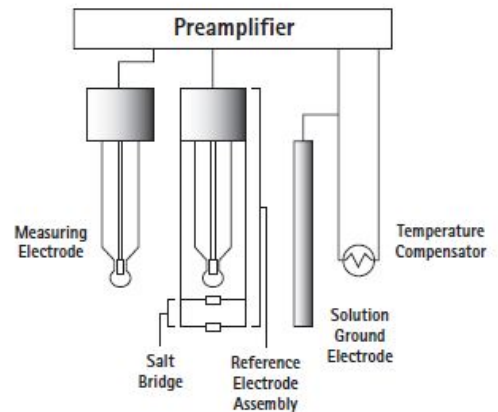

$$\frac{(E_m - E_g) - (E_r - E_g)}{(E_m - E_r)}$$

Another advantage of the differential electrode technique is the third "ground electrode." Since ground loop currents will pass through only this electrode, and not through the reference electrode, the overall pH signal output is unaffected by the ground loop potential.

## The Measuring Electrode

The galvanic voltage output produced by a measuring electrode will depend on the ionic activity of the species of ions which the electrode was designed to measure. In the case of pH electrodes, it is the hydrogen ion activity.

Based upon the Nernst equation, at 25° C, the output of a pH measuring electrode is equal to 59.16 mV per pH unit. At 7.00 pH, which is the isopotential point for a perfect electrode, the output is 0 mV. As the solution pH increases (less acidic), the mV potential becomes more negative. Conversely, as the solution pH decreases (more acidic), the mV potential becomes more positive.

The glass measuring electrode has been adopted as the measuring element for most pH sensors in use today. The measurement is predicated on the principal that a hydrated gel layer forms between the outer surface of the glass and the aqueous solution being measured (*Figure 8*).

Figure 8. Ion Migration Between Aqueous Solution and pH Sensitive Glass

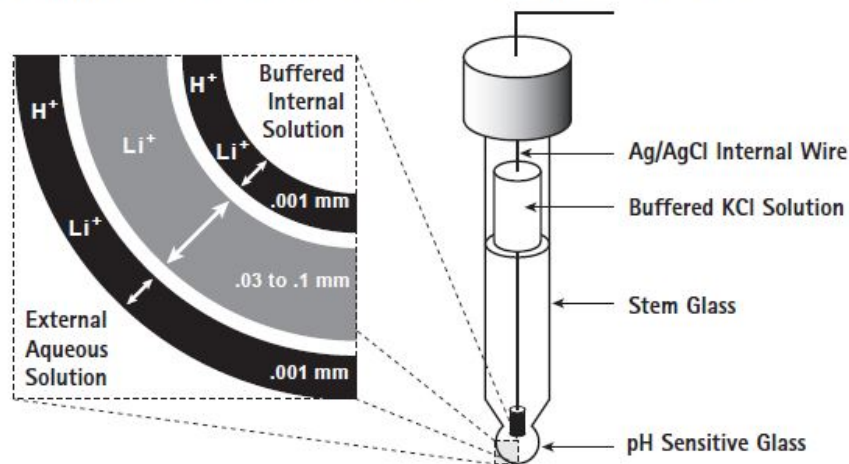

The measuring electrode's internal wire element has a potential,  $E_3$ , with respect to the internal fill solution (*Figure 9*). Another potential,  $E_2$ , exists between the internal fill solution and the inside surface of the glass.

Depending on the pH of the solution being measured, hydrogen ions will migrate into or out of the gel layer. In an alkaline solution, hydrogen ions migrate out of the gel layer and a negative charge is developed on the outer gel layer. Because the electrode's internal fill solution is at a constant pH value, the internal potential remains constant. Therefore, the potential that is measured across the glass membrane is the result of the difference between the inner and outer electrical charge.

## Asymmetry Potential

When a pH electrode is immersed in a solution with the same pH as its internal fill solution, there should not be a measurable potential across the glass membrane. If such a potential exists, it is known as an **asymmetry potential** (*Figure 9*). In practice, this potential is usually a few millivolts or less for a new, properly stored electrode.

Factors that limit the ability of the ion exchange mechanism cause asymmetry potential. This includes a dehydrated electrode, using the electrode in a non-aqueous solution, or plugging and/or coating of the glass surface. Asymmetry potential is also referred to as the difference in potentials between the measuring and reference electrodes when immersed in a zero solution. This potential constantly changes depending on the pH value of the solution, temperature, age of the measuring electrode, and its type of glass formulation.

Calibration of the pH sensor, with the measuring instrument, will compensate for any asymmetry potential(s). Proper cleaning of the electrode and reference junction prior to calibration is essential. Long-term usage of the sensor between calibrations will show changing pH as a function of the asymmetry potential(s) in combination with actual changes of the pH value. Once the asymmetry potential has increased beyond the instrument compensation capability through calibration, the sensor must be renewed, if possible. If changing the internal fill solution and/or junction does not reduce the asymmetry potential, the sensor is beyond refurbishing and must be replaced.

Figure 9. Asymmetry Potential

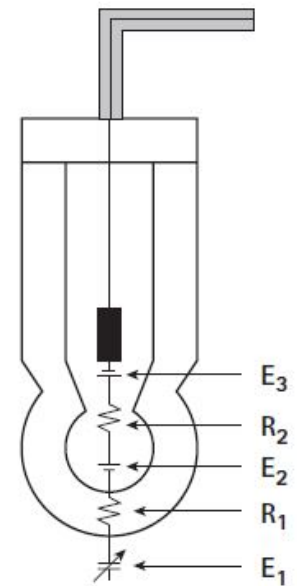

### Sodium Ion Error

Although the pH glass measuring electrode responds very selectively to hydrogen ions, there is a small interference caused by similar ions such as lithium, sodium, and potassium. The amount of this interference decreases with increasing ion size. Since lithium ions are normally not in solutions, and potassium ions cause very little interference, sodium ions present the most significant interference.

**Sodium ion error**, also referred to as alkaline error, is the result of alkali ions, particularly sodium ions, penetrating the glass electrode silicon-oxygen molecular structure and creating a potential difference between the outer and inner surfaces of the electrode. Hydrogen ions are replaced with sodium ions, decreasing the hydrogen ion activity, thereby artificially suppressing the true pH value. This is the reason pH is sometimes referred to as a measure of the hydrogen ion activity and not hydrogen ion concentration.

Sodium ion interference occurs when the hydrogen ion concentration is very low and the sodium ion concentration is very high. Temperature also directly affects this error. As the temperature of the process increases, so does the sodium ion error.

Depending on the exact glass formulation, sodium ion interference may take effect at a higher or lower pH. There is no glass formulation currently available that has zero sodium ion error. Since some error will always exist, it is important that the error be consistent and repeatable. With many glass formulations, this is not possible since the electrode becomes sensitized to the environment it was exposed to prior to experiencing high pH levels. For example, the exact point at which the sodium ion error of an electrode occurs may be 11.50 pH, after immersion in tap water, but 12.50 pH after immersion in an alkaline solution.

Controlled molecular etching of special glass formulations can keep sodium error consistent and repeatable. This is accomplished by stripping away one molecular layer at a time. This special characteristic provides a consistent amount of lithium ions available for exchange with the hydrogen ions to produce a similar millivolt potential for a similar condition.

## Acid Error

Acid error affects the low end of the pH measuring scale. As pH decreases and the acid error begins, water activity is reduced due to higher concentrations of acid displacing water molecules. The thickness of the hydrated gel layer becomes thinner due to acid stripping. This effect has a negative influence on the mV output, thereby causing the measured pH value to remain higher than the theoretical pH value. The acid error changes very little with temperature. Over time, an upward drift of pH in acidic solutions is indicative of acid error.

Since acid error is usually observed below 1.00 pH and most process applications are well above that, it is fairly uncommon. Process monitoring equipment is usually set to respond to a setpoint at which appropriate action is taken to return the pH to the setpoint value when the pH rises above or falls below it. For example, the controller will add caustic to a solution that is below the setpoint. It does not matter that the true pH value is 0.91 pH and is not accurate, since the controller will be calling for caustic addition until the setpoint is reached.

## Temperature Effects

Temperature affects the pH measurement in two ways. The first is a change in pH due to changes in dissociation constants of the ions in the solution being measured. This implies that as solution's temperature changes, the pH value also changes. Presently available instrumentation cannot account for this change because the dissociation constants vary from solution to solution.

The second reason temperature affects the pH measurement, is glass electrode resistance. Since the glass measuring electrode is an ionic conductor, it stands to reason that the resistance of the glass will change as the solution temperature changes. As temperature rises, resistance across the glass bulb decreases. This change in resistance versus temperature is constant and can be calculated depending on the specific type of glass formulation of the electrode.

In practical terms, electrode resistance drops ten-fold for every 30° C rise in temperature. For example, an electrode with a 100 megohm resistance at 25° C will decrease to 10 megohm at 55° C. Assuming that the theoretical pH of the solution is constant, the changing electrode resistance will incorrectly affect the pH reading, requiring the use of temperature compensation in the measurement circuit.

A typical glass electrode at 25° C can have a resistance of 100 megohms. Typical ranges can vary from 20 to 800 megohms. In contrast, the resistance range for reference electrodes varies from 100 to 5000 ohms.

The resistance value of the measuring electrode is based on a number of influences: solution temperature, glass formulation, glass thickness, the shape of the measuring electrode tip (*Figure 10*), its surface measuring area, and the physical state of the hydrated gel layer.

Although temperature will not affect the electrode's response speed, the thickness of the glass will. A thicker glass will be more durable, but it also has more resistance, a noisier signal and a longer response time. A thinner glass will have less resistance and a quicker response time, but will be more fragile.

**Figure 10. Measuring Electrode Tip Shapes**

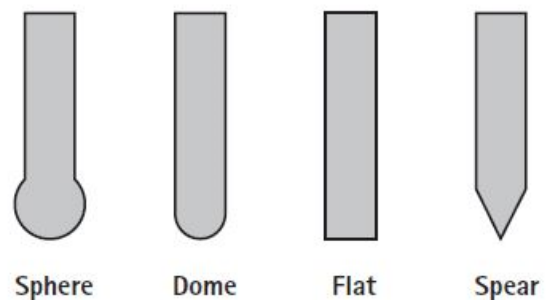

With high electrode resistance comes the impact of capacitance coupling and electrical noise (*Figure 11*). The lead wire exiting the measuring electrode is prone to picking up spurious electrical signals—an effect known as hand capacitance. Similar to extending a radio antenna for pulling in distant stations, the longer the electrode lead wire length, the more prone the electrode is to picking up interference. In the case of hand capacitance, merely waving a hand next to the cable will cause the measuring instrument display to change erratically.

Shielding the electrode and using high quality cable in the manufacturing process can minimize the effects of electrical noise. Shielding is usually accomplished by incorporating a metallic band within the glass measuring electrode body. This band extends from the base of where the bulb is coupled to the electrode body, up the shaft, and back to where the cable exits the body. When the electrode is immersed in the solution, the band effectively shields the measuring element from stray interference through the solution. Combination electrodes are inherently shielded by the reference fill solution that surrounds the entire measuring element.

When taking measurements, it is best to immerse a majority of the metal band (the measuring electrode shaft) into the solution. However, the area where the electrode shaft joins a cap or cable connection should not be immersed. As for shielding the glass bulb, the solution being measured acts as the shield.

Most instruments presently manufactured compensate for electrode resistance changes resulting from solution temperature fluctuations. This compensation is almost always accomplished automatically using a temperature-sensitive device as part of the measuring circuit. In other cases, it is accomplished manually with an adjustment to the feedback circuit of the instrument's electronics. On analog instruments, this is achieved by setting a dial to the correct temperature setting. For microprocessor-based instruments, a temperature value corresponding to the actual temperature of the solution being measured is manually entered.

## The Reference Electrode

The glass measuring electrode is significant, but only as part of the overall system used to measure pH. Its half-cell potential must be combined with the other half-cell potential of the reference electrode to complete the measurement circuit. Both of these elements, when submerged into a solution, generate a pH measurement when connected to a measuring device. For the measuring electrode to provide an accurate measurement, the reference electrode must have a constant and stable potential. Any deviation in its potential will cause the overall potential to change, thereby causing the pH reading at the measuring device to also change.

The reference electrode consists of a silver wire coated with silver chloride that is immersed in an electrolyte solution. This wire must be electrically connected with the solution being measured. This is accomplished through a porous junction, commonly called a salt bridge, which physically isolates the electrolyte and wire from the solution being measured. The electrolyte solution must have a high ionic strength to minimize resistance and not affect the solution being measured, and must remain stable over large temperature swings. Potassium chloride (KCl) solutions that are 3.0 molar, 3.5 molar, or saturated have been used successfully for many years. This reference wire and electrolyte combination is the silver/silver chloride reference system. Other types of reference systems are also manufactured for specific measurement needs. These alternate reference systems consist of calomel, thalomid or mercury.

**Figure 11. Electrical Potentials of Measuring and Reference Electrodes**

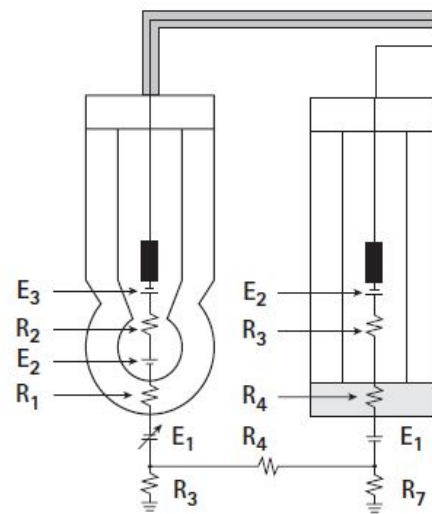



## The Reference Junction

The reference junction is located at the measuring end of the reference electrode (or reference electrode assembly for a differential pH sensor). The reference junction is also referred to as a "**salt bridge**," liquid junction, or frit. Its purpose is to interface physically and electrically with the internal electrolyte and the solution being measured. This reference junction completes the current path from the glass measuring electrode to the reference electrode.

The reference junction must be chemically inert, so it does not to interfere with the ion exchange process but allows small amounts of electrolyte to flow through it, while maintaining a consistent low resistance value. The reference junction is constructed of porous materials such as wood, Teflon, Kynar, ceramic, or more exotic materials such as asbestos or quartz fibers. There is also a ground glass sleeve junction that, just as the name implies, uses two ground glass surfaces mated to one another. These two surfaces are fit tightly together, but they allow electrolyte to permeate between them. The size of the junction material usually corresponds to the size of the reference wire, and it is usually cylindrical. Its diameter is typically 1/16 inch to 1/8 inch and its length is between 1/8 inch and 1/2 inch. Annular junctions, which surround the reference electrode, are also used. They are available in a wide range of materials and sizes.

For current to flow, the junction must be able to conduct electrons. This current flow is established by allowing electrolyte solution (and to some detriment, the solution being measured) to penetrate the structure of the junction. The junction is designed to enable small amounts of the reference electrode electrolyte to leach out, or flow, through it into the solution being measured. As the electrolyte flows out through the junction, it prevents the solution being measured from flowing back into the reference system and contaminating the KCl solution, or attacking the silver and silver chloride (Ag/AgCl) wire.

However, there are times when the solution being measured does penetrate the junction and contaminate the reference system. The solution being measured may be under sufficient pressure to force it back through the junction into the reference system. With replaceable junctions, an incorrectly installed junction (missing O-ring, torn O-ring, or cross threading) will allow the solution being measured to flow unimpeded past the junction. Measuring a solution that tends to coat or plug the junction is also detrimental, since it stops the electrolyte flow and increases the resistance of the junction.

Theoretically, the resistance of the junction and the chemical make-up of the reference system are assumed to be constant during calibration and measuring. However, due to junction contamination, junction plugging, electrolyte dilution, and chemical attack of the silver/silver chloride wire, the resistance is always changing, as is the chemical composition of the whole reference electrode. Consequently, this highlights the importance of frequently calibrating to compensate for these factors.

## Junction Potentials

When comparing pH readings between two or more pH sensors, there are usually differences between the readings. The comparisons may be between a process solution reading and a grab sample reading. In this case, the differences are usually caused by the process reading being under pressure, while the laboratory reading is not. Gases are normally entrained (dissolved) in the process solution, but dissipate from the grab sample and no longer affect the pH reading. Additionally, the grab sample and process solution temperatures may be far enough apart to affect the pH reading.

Using sensors of different types can also cause differences in readings. Typically, combination electrodes or differential pH sensors for process measurement and electrode pairs for laboratory measurement, or any

combination thereof can be the cause. The sensor for the process reading is usually a sealed device, whereas the laboratory electrode pair is open to the atmosphere to enable refilling of electrolyte. Sealed references will usually produce different zero points than those of laboratory refillable electrodes, resulting in different pH readings.

Differences in readings may not necessarily be due to actual pH differences. Effects of junction potential, electrical grounding, electrode membrane coating, and dissociation constants of the solution being measured can greatly affect the millivolt output of the measuring and reference electrodes. Additionally, chemical compounds or particulate matter in the solution can disable the reference electrode or junction. The process can also contaminate the silver/silver chloride reference system. Sulfur compounds, heavy metals, and strong oxidizing and reducing agents can attack the silver/silver chloride reference system. The resultant reaction of this attack will form silver complexes or precipitate elemental silver that can block the pores of the junction or produce oxidation-reduction potentials across the junction. In either case, this results in an offset reference potential.

### **Gel-filled reference Electrode**

The gel-filled reference electrode uses a gelling agent added to the reference electrolyte solution. The purpose is to slow down the effects of contamination on the reference electrolyte by process migration through the porous junction. It is also more difficult for this gelled electrolyte to be forced out of the reference system cavity while the process undergoes periods of temperature and pressure cycling. The gel tends to last longer than conventional electrolyte solution under normal circumstances. Higher temperatures and processes that attack or strip the gelling agent when it is migrating through the porous junction will tend to break down the gelling agent.

### **Buffers**

The term buffer is defined as "a substance that absorbs an impact, protects against a shock, resists change, or maintains a relative acid/base concentration within a specific range."

With regard to pH, buffers are solutions in which the pH remains unchanged when small amounts of an acid or a base are added. A buffer is a solution of a weak acid or base and one of its salts, that must resist a change in its pH value. A buffered solution contains chemicals that will not readily allow a change in pH value when it is being neutralized or changed by dilution.

An example of a poor buffer solution is trisodium phosphate. A 0.06% solution at room temperature has a pH of 12.0. A solution with half as much concentration (0.03%) has a pH of about 11.7, while a solution with twice as much concentration (1.2%) has a pH of 12.5. It is evident that an increase or decrease in solution concentration will also increase or decrease the pH.

An example of a good buffer is a solution of sodium sesquicarbonate. The pH value for this solution, in the same concentrations and with the same temperature as the previous example, remains consistent. This buffer indicates that it is a more stable solution.

### **Calibration**

pH electrodes must be calibrated from time to time to maintain measurement accuracy. It is a fact that the performance of a pH sensor degrades over time. The time period and related loss of sensor performance varies considerably with each application and its unique conditions.

Specifically, calibration is performed to compensate for changes in potential within the measuring and reference electrodes, as well as any change of potential between them. The electrodes are usually matched at the factory so that the measuring electrode and reference electrode, when put in a zero solution, (7.0 pH buffer) provide a zero mV output.

Differences or changes in potential can be caused by one or more of the following factors:

- **Contamination of the reference electrolyte solution.** The solution being measured is allowed to migrate through the junction, entering the electrolyte cavity, thereby changing its composition and altering its electrochemical reaction
- **Electrolyte evaporation or depletion.** As the solution being measured enters the reference electrolyte cavity, the electrolyte is displaced. Under the right combination of temperature and pressure conditions, the electrolyte, process solution, or a mixture of both can be drawn out of the cavity. As the level changes, so does the potential output, until finally, the level drops below the silver/silver chloride wire to cause an open measuring circuit.
- **Chemical attack of the silver/silver chloride wire.** As the solution being measured enters the reference electrolyte cavity, certain changes may occur that poison the silver/silver chloride wire. This physical and chemical attack on the wire changes its properties so that the whole reference system no longer produces the same output as it did prior to the attack. In some cases, this change in output will remain constant, while in others it may be constantly degenerating over time.
- **Junction potential.** When exposed to the solution being measured, the reference junction may become contaminated or plugged. This changes the resistance of the reference electrode, thereby changing its output.
- **Aging of the measuring electrode.** As the glass measuring electrode is exposed to the solution being measured, the electrode is continuously attacked. The gel layer that is formed at the electrode tip undergoes continuous change, which ultimately alters its output. This "aging" is continuous. The glass measuring electrode never becomes stable. As aging progresses, the gel layer becomes thicker, thereby affecting its output.

Taking into account any one of these factors, let alone the possibility of two or more of these conditions occurring, it is easy to see why a pH sensor must be recalibrated in a pH buffer solution to maintain measurement accuracy.

Calibration also involves checking the slope of the measuring electrode. Slope defines the ability of the measuring electrode to change its output by 59.16 mV per pH unit at 25° C. For previously stated reasons, virtually all pH instruments use a slope adjustment to compensate for the measuring electrode's inability to accurately produce its output signal. The slope adjustment is made using a buffer that has a value at least 3 pH units from the zero buffer (7.0 pH).

Buffers are used when calibrating pH sensors to compensate for any inherent offsets of the sensor. Typically, 4 pH and 7 pH buffers are used to perform the calibration. For best calibration accuracy, use buffers with values that are close to the normal pH value of the solution being measured. For example, if the solution being measured is normally 2 pH, it is best to use 4 pH and 7 pH buffers rather than 7 pH and 10 pH buffers. Ideally, one of the buffer values for this example should be 2 pH.

Adhere to the standard practice of using calibration buffers that are at least three pH units apart. This difference is intended to provide the electrode with sufficient change, enabling its slope to be plotted over a wide area. When adjusting the zero and slope, carefully follow the equipment manufacturer's instructions to avoid inaccurate results. When calibrating an instrument without temperature compensation capability, the temperatures of the buffers need to be known.

Figure 12 indicates how the value of a pH buffer is affected by changes in temperature.

For instruments with automatic temperature compensation, the proper calibration technique is to allow the sensor and buffer temperatures to equalize, and to rinse the sensor in *distilled* water between buffers. This will remove residual contaminants from the sensor, prevent buffer contamination carryover, and prolong the buffer solution. Never reuse buffers by pouring the used buffer portion back into the bottles. Always discard buffers immediately after use.

Figure 12. pH Buffer Values versus Temperature Changes

Temperature	4.01 pH buffer	6.87 pH buffer	9.18 pH buffer	12.45 pH buffer
0°C	4.00	6.98	9.46	13.42
25°C	4.01	6.87	9.18	12.45
50°C	4.06	6.83	9.01	11.71
70°C	4.13	6.85	8.92	11.22
100°C	4.25	6.90	8.81	10.65

The following graphs show the temperature versus pH curve in a more representative form:

Figure 13. Plotted pH versus Temperature Values for 4.01 pH Buffer

#### Plotted Points

Temperature °C	pH
0	4.00
25	4.01
50	4.06
70	4.13
100	4.25

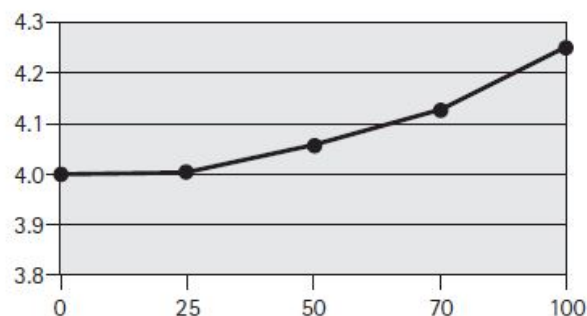

Figure 14. Plotted pH versus Temperature Values for 6.87 pH Buffer

#### Plotted Points

Temperature °C	pH
0	6.98
25	6.87
50	6.83
70	6.85
100	6.90

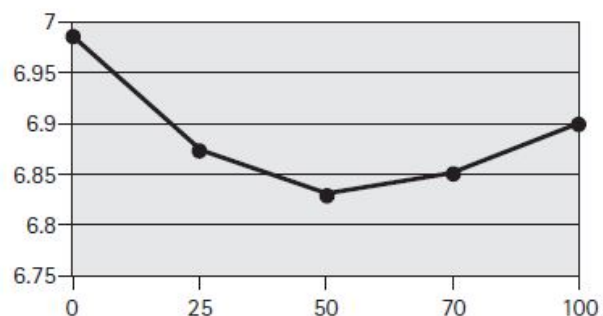

Figure 15. Plotted pH versus Temperature Values for 9.18 pH Buffer

Plotted Points

Temperature °C	pH
0	9.46
25	9.18
50	9.01
70	8.92
100	8.81

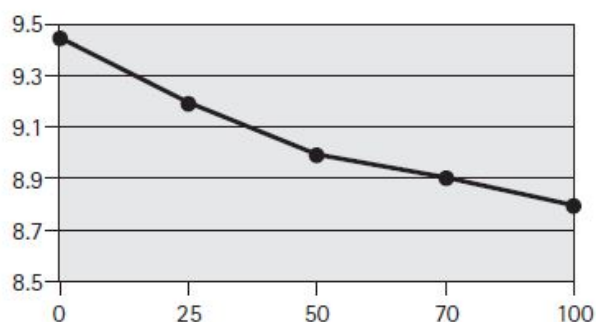
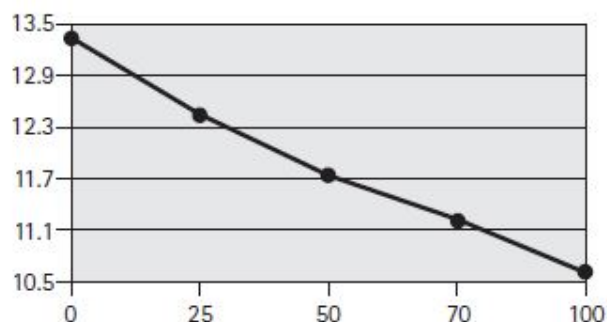

Figure 16. Plotted pH versus Temperature Values for 12.45 pH Buffer

Plotted Points

Temperature °C	pH
0	13.42
25	12.45
50	11.71
70	11.22
100	10.65



**NOTE:** pH 10 buffer is also readily available, but it is not as stable as pH 7 and pH 4 buffers, particularly at extreme temperatures. When pH 10 buffer is exposed to air, it absorbs carbon dioxide. As this occurs, the buffer becomes more acidic and is no longer dependable as a calibration reference solution. Even when stored in sealed plastic bottles, the carbon dioxide molecules permeate the plastic bottle and over time, this will cause the same reaction.

## Chapter 5 – CARE OF pH ELECTRODES

### Dehydration

Left out of solution, the pH glass membrane will become dehydrated. After this happens, the pH sensor will have slower response and a higher than normal impedance when it is put back into operation. Repeated dehydration and re-use will dramatically reduce the normal service life of the pH sensor. Prolonged dehydration will cause the glass membrane to fail completely.

If the reference electrode becomes dehydrated, it will no longer operate properly. The electrolyte will leach out of the electrode cavity, through the junction(s), forming salt crystals on the junction surface. Over time, leaching will weaken the electrolyte potential, and may also cause a phenomenon known as a bridging effect. Both of these conditions will increase the output impedance, making the reference electrode output unstable. With continued dehydration, the impedance will rise to a level that becomes unusable to the pH meter.

### Factors Detrimental to Electrode Life

A pH electrode operates similarly to a hydrogen electrode within the range of 0.00 - 12.00 pH (where the alkali error affects the reading). This is known as a sodium ion error (discussed earlier in *Chapter 4 – The pH Sensor*). Within this range, the output slope of the electrode corresponds to the theoretical 59.16 mV as defined by the Nernst equation.

As with all glass, pH glass is susceptible to chemical attack. Temperature changes can alter the rate of this attack. For every 30° C rise in temperature, the rate of attack increases ten-fold. Accordingly, process solutions with elevated temperatures shorten electrode life. Strong acids and strong alkaline solutions, to a greater extent, attack the glass membrane. Even neutral solutions that contain high concentrations of alkali ions, sodium ions in particular, attack the glass. Using a pH sensor with a glass formulation that is inappropriate for the application may render the sensor inoperable after only a short time without any visible glass defects.

Hydrofluoric acid (HF) will readily poison the glass membrane when the pH is below 6.00. The greater the fluoride ion concentration, the faster the electrode will fail. The fluoride strips away the gel layer of the glass membrane rendering it inoperative.

A special electrode manufactured from antimony is available for measuring pH in solutions containing HF. The antimony electrode exhibits similar properties to glass electrodes within certain limits. One drawback is that the repeatability and speed of response for an antimony electrode is inferior to that of a glass electrode. Also, antimony electrodes are only linear between 3.0 and 8.0 pH, and should only be specified when the presence of hydrofluoric acid dictates their use.

### Transportation

Freezing, extreme heat, vibration, and mechanical shock must be avoided when transporting electrodes, whether within a facility, or from one facility to another. Always try to reuse the original box and packing materials to transport electrodes.

When shipping the electrode using motor freight, select a carrier that will guarantee that the package will not be exposed to extreme temperatures. Usually sending the electrode by an overnight delivery service ensures that the package will not be exposed to the elements long enough to damage the electrode.

## Storage

pH sensors (electrode pairs, combination electrodes, and differential styles) should be stored in ambient conditions between 10 and 30° C. Protective caps and solution storage caps should be kept intact and installed on the end of the sensor as provided by the manufacturer.

The best solution for storage purposes is a 3 to 3.5 M KCl solution. This solution provides a neutral to slightly acidic environment for the glass electrode, and will not impose a memory on the glass, much as Ni-Cad batteries can have memories imposed upon them when they are not fully discharged prior to recharging. Should KCl solution be unavailable, appropriate substitutes in order of preference are:

1. pH 4 buffer
2. Distilled water
3. Tap water

Under these conditions, the glass measuring and reference electrodes can be stored for three to five years.

**NOTE:** Periodically check to verify that the storage solution has not evaporated.

## Chapter 6 – COMMON APPLICATIONS

### Cooling Tower Control

The purpose of a cooling tower is to cool down industrial processes and provide cooled water for HVAC control. The cooled process water is directed through the process, where it absorbs heat, and is then sent back to the tower to be re-cooled. Large amounts of water are required as evaporation occurs during the cooling cycle. Since water is an expensive commodity, primary concerns are efficiencies in cooling tower design and chemical treatment of the water being used.

Hot water entering the cooling tower is sprayed through cooler air to speed evaporation. For efficient cooling, it is very important to maintain a large surface area for exposing the water to the air for an extended period of time. These heat transfer surfaces must be protected from corrosion and scale. After the water is cooled, it is collected in a sump and pumped back through the process piping.

Proper control of a number of parameters will keep the tower operating efficiently and prevent damage to vital parts from scale, corrosion, and biological growth. As air flows through the tower, airborne contaminants are picked up by the water/air interface. These contaminants would be carried through the system if they were not controlled prior to distribution.

pH is one of many parameters that controls the water chemistry of the tower. Maintaining a pH level between 6.0 and 7.0 is fairly common. Depending on the pH of the water supply to the tower—lake, stream, or municipal water supply—either an acid or caustic control scheme is used to maintain the pH in this range.

### Food Processing

Canning plants use caustic soda (NaOH) in their fruit and vegetable peeling operations. Prior to disposal of the wastes, the pH must be neutralized. Usually this is accomplished using CO<sub>2</sub> (carbon dioxide) as a reagent. The CO<sub>2</sub> is injected into stainless steel pipelines to lower the caustic waste, typically from a pH of 12.7 to 9.5. The amount of CO<sub>2</sub> reagent added to the peeling wastes is determined by the resultant pH value of the waste stream at the plant discharge point.

The neutralized waste material is recycled and used as both wet and dry animal feed for surrounding farms.

### Coal Industry

Water run-off from coal mining operations is acidic and must be collected and treated prior to contact with surrounding water sheds. Anhydrous ammonia is typically used as a reagent to increase the pH. Values of coal run-off water have been known to be as low as 2.05 pH.

Under atmospheric conditions, anhydrous ammonia is a vapor. Stored in a tank under pressure, it is a liquid. Specially engineered systems can feed either liquid or vaporous anhydrous ammonia. Depending on the system design criteria, each form has its particular advantages and disadvantages. When feeding anhydrous ammonia in vapor form, an electrically heated vaporizer must be used. Ammonia is easier to measure and control if applied as a vapor.



Run-off water is collected or pooled. The pH of this effluent is measured and then compared to the control setpoint. If the pH is below the acceptable level, the pH controller controls a valve to allow the reagent to be added to the effluent and mixed until the optimum pH value is reached. After the collected water is appropriately treated, it is discharged.

## **Plating Waste Treatment**

The plating industry produces wastes of cyanides, chromates, acids, and alkali cleaners. Each must be treated prior to discharge. Typically, pH and Oxidation Reduction Potential (ORP) measurement and control are used in combination to neutralize and detoxify these solutions. The majority of applications involve batch treatment in holding tanks with good mixing.

Treating toxic solutions before they become part of the effluent flow is preferable to final stage treatment. Cyanide and chromate wastes are just two examples that use this scheme. In this scenario, a tank with the treatment chemicals is downstream from the plating tank. Rather than being rinsed from the parts and treated later, carry over chemicals are treated within this tank.

Chlorine or sodium hypochlorite is used to oxidize cyanide to a less toxic cyanate. Proper care must be taken to maintain an alkaline pH so that the pH of the solution does not fall, producing deadly cyanide gas. Caustic is added to the process through a solenoid valve controlled by the pH measurement system. The pH during this treatment phase must be closely maintained between 9.98 and 10.02 pH. The reaction is furthered when the ORP value, monitored by an ORP measurement system, reaches a pre-determined point for a specified time.

The final step involves either pumping the solution to another tank to extract the heavy metals, or adding acid to the solution to get a final 7.5 to 8.0 pH level. This process starts the oxidation of the cyanate. After proper pH adjustment, the cyanate is oxidized to carbon dioxide, nitrogen, and water by adding chlorine or hypochlorite. Again, proper monitoring of ORP during this step ensures a completed reaction.

## **Ultrapure Water**

The measurement of pH in ultrapure water requires some special considerations. Because of its unique properties, ultrapure water has been called the world's greatest solvent. Its purity and solvent properties prevent corrosion of wetted parts in boilers in power generating plants. It is used as a cleaner to wash contaminants from electronic microchips in the electronics industry, and it provides the base for injectable medicines in the pharmaceutical industry.

Chemically pure water consists of two atoms of hydrogen and one atom of oxygen. It is odorless and colorless. Italian scientist Stanislao Cannizzarro defined the chemical formula of the water molecule,  $H_2O$ , in 1860. Absolutely pure water does not last long because it dissolves nearly everything it comes into contact with, thereby retaining some of the properties of the contacted material. It readily absorbs carbon dioxide when exposed to the atmosphere. It is very difficult to make pure water even through repeated distillations.

When heated, water boils producing steam (water vapor) as a byproduct. Considered pure, steam quickly absorbs atmospheric elements such as carbon dioxide that quickly change the water to something other than ultrapure water. Because ultrapure water has no buffer capacity, the slightest contamination will change its pH value.

Pure water is a very good electrical insulator. This makes it especially difficult to conduct electrons between the measuring and reference electrodes of a pH sensor. Within the pH electrode measuring circuit, this causes a high resistance that is prone to electrical noise, slow electrode response, hand capacitance effects, and static

buildup. This static buildup is even more prevalent when pure water flows through plastic piping. A common phenomenon stemming from this buildup of static charge is referred to as a streaming current potential. This potential will affect the pH reading by providing false electrical potentials to the measuring and reference electrodes. These potentials can cause a variable or constant voltage offset to be applied to the electrodes, making the pH measurement meaningless. After repeated exposure to ultrapure water, the reference junction will exhibit a high resistance due to its insulating properties, causing drift and unstable calibration.

Electrodes for measuring ultrapure water are specialized and are usually mated with a metal, grounded flow assembly. The metal flow assembly helps shield the reading from electrical noise and hand capacitance. A slow process flow rate through the assembly also provides ample residence time for the measurement to occur and, to some degree, eliminates streaming current potentials.

The electrode assemblies have gel-filled references or flowing junctions so a fast and efficient potential is established between the junction and the solution being measured. The electrolyte passing through the junction provides this potential with a minimal chance of junction plugging or fouling. The only drawback of this design may be the contamination of the process solution with the electrolyte. Putting the entire measuring loop into a bypass assembly and then directing the sample discharge to drain will keep a constant pressure on the measuring electrode. This will also negate the problem of sending a process sample, contaminated with KCl electrolyte, back into the process.

## BIBLIOGRAPHY

- Arthur, Robert M. 1982. *Application of On-line Analytical Instrumentation to Process Control*. Arthur Technology.
- Bates, Roger G. 1973. *Determination of pH, Theory and Practice*.
- Beckman 1983. *The Beckman Handbook of Applied Electrochemistry*. Beckman Instruments, Inc.
- Chemtrix. pH in Plain Language. Chemtrix, Inc.
- Gray, David M. 1994. *On-line High Purity pH Measurement*. Leeds and Northrup.
- Ingold, 1989. *Practice and Theory of pH Measurement*. Ingold Messtechnik AG.
- McMillan, Gregory K. 1994. *pH Measurement and Control; Second Edition*. Instrument Society of America.
- Merriman, Dale C. 1993. *Reference Junction Potential Differences Between Laboratory and Process Instrumentation*. Instrument Society of America.
- Moore, Ralph L. 1978. *Neutralization of Waste Water by pH Control*. Instrument Society of America.
- Schott Gerate. *Electrodes and Accessories for Technical Service*. Schott Corporation.

## GLOSSARY

**Activity:** A thermodynamic term for the apparent or active concentration of a free ion in solution. It is related to concentration by the activity coefficient.

**Asymmetry Potential:** The potential developed across the glass membrane of the measuring electrode with identical solutions on both sides. Also a term used when comparing measuring electrode potential in pH 7 buffer.

**ATC:** Automatic temperature compensation.

**BNC:** A quick disconnect electrical connector used to interconnect and/or terminate coaxial cables.

**Buffer Capacity:** A measure of the ability of the solution to resist pH change when a strong acid or base is added.

**Buffer:** Any substance or combination of substances which, when dissolved in water, produces a solution that resists a change in its hydrogen ion concentration when acid or alkali is added.

**Calibration:** The process of adjusting an instrument or compiling a deviation chart so that its reading can be correlated to the actual value being measured.

**Conductance:** The measure of the ability of a solution to carry an electrical current.

**Dissociation Constant:** A value which quantitatively expresses the extent to which substances dissociate in solution. The smaller the value of  $K$  is, the less dissociation of the species in solution. This value varies with temperature, ionic strength, and the nature of the solvent.

**Drift:** A change of a reading or a setpoint value over a period of time due to several factors including change in ambient temperature, time, and the line voltage.

**Electrode Potential:** The difference in potential established between an electrode and a solution in which it is immersed.

**Electrolyte:** Any substance in a solution that will conduct an electric current. Acids, bases, and salts are common electrolytes.

**Filling Solution:** A solution of defined composition, also called an electrolyte, that provides a chemical reaction as well as an electrical potential between an internal element and the process being measured. An example is the solution sealed inside a pH glass bulb, typically KCl. A filling solution normally is a buffered chloride, which provides a stable potential and a specific zero potential point. In a reference electrode, the electrolyte, also called the reference filling solution, surrounds the silver/silver chloride wire and periodically requires replenishing.

**Hydrogen Ion Activity:** Activity of the hydrogen ion in solution. It is related to hydrogen ion concentration ( $\text{CH}^+$ ) by the activity coefficient for hydrogen ( $f_{\text{H}^+}$ ).

**Impedance:** The total opposition (resistive plus reactive) to electrical flow.

**Input Resistance (Impedance):** The input resistance of a pH meter is the resistance between the measuring electrode terminal and the reference electrode terminal. A voltage division between the total electrode resistance and the input resistance always affects the potential of a pH measuring electrode circuit.

**Internal Reference Electrode Wire:** The silver/silver chloride wire used in a reference electrode.

**Isopotential Point:** A potential which is not affected by temperature changes. It is the pH value at which  $dE/dt$  for a given measuring/reference electrode system is zero. Theoretically, for a glass measuring electrode and SHE reference electrode, this potential exists when immersed in pH 7 buffer.

**Logarithmic Scale:** A method of displaying data (in powers of ten) to yield maximum range while keeping resolution at the low end of the scale.

**Membrane:** The pH sensitive glass bulb is the membrane across which a potential difference is developed from an ion- exchange reaction. The membrane separates the electrolyte in the measuring electrode from the solution being measured.

**Millivolt (mV):** A unit of electromotive force. It is the difference in potential required to make a current of 1 millampere flow through a resistance of 1 ohm. One millivolt equals one thousandth of a volt.

**Molality:** A measure of concentration expressed in moles per kilogram of solvent.

**Molarity:** A measure of concentration expressed in moles per liter of solution.

**Nernst Equation:** A mathematical description of electrode behavior in which: E is the total potential, in millivolts, developed between the measuring and reference electrodes; Ex varies with the choice of electrodes, temperature, and pressure;  $2.3RT/nF$  is the Nernst factor (R and F are constants, n is the charge on the ion including sign, and T is the temperature in degrees Kelvin); and  $a_i$  is the activity of the ion to which the electrode is responding.

**Nernst Factor (Slope):** The term  $2.3RT/nF$  in the Nernst equation, when  $T = 25^\circ \text{C}$ , is equal to 59.16 mV when  $n = 1$ , and 29.58 mV when  $n = 2$ . The term n is the sign of the charge on the ion. The Nernst factor varies with temperature.

**pH Junctions:** The junction of a reference electrode or combination electrode, typically a liquid junction, is a permeable membrane through which the electrolyte migrates.

**Salt Bridge:** The salt bridge of a reference electrode is that part of the electrode which is in contact with the electrolyte, establishing the electrolytic connection between the reference system and the solution being measured. An "auxiliary" salt bridge is a glass tube open at one end for electrolyte filling, and connected to the reference electrode cavity at the other end. This type of salt bridge, used for special applications, increases the electrolyte capacity.

**Span:** The difference between the upper and lower limits of a range expressed in the same units as the range.

**Stability:** The quality of an instrument or sensor to maintain a consistent output when a constant input is applied.

**Standardization:** A process, also known as calibration, of equalizing the measuring electrode and reference electrode millivolt output potentials in one standardizing solution (buffer) so that potentials developed in unknown solutions can be interpreted as pH values.

**Thermistor:** A temperature-sensing element composed of sintered semiconductor material which exhibits a large change in resistance proportional to a small change in temperature. Thermistors usually have negative temperature coefficients.

LITG004

© Hach Company, 2010. All rights reserved.

*In the interest of improving and updating its equipment, Hach Company reserves the right to alter specifications to equipment at any time.*